

# CURIOUSA

## VENUS

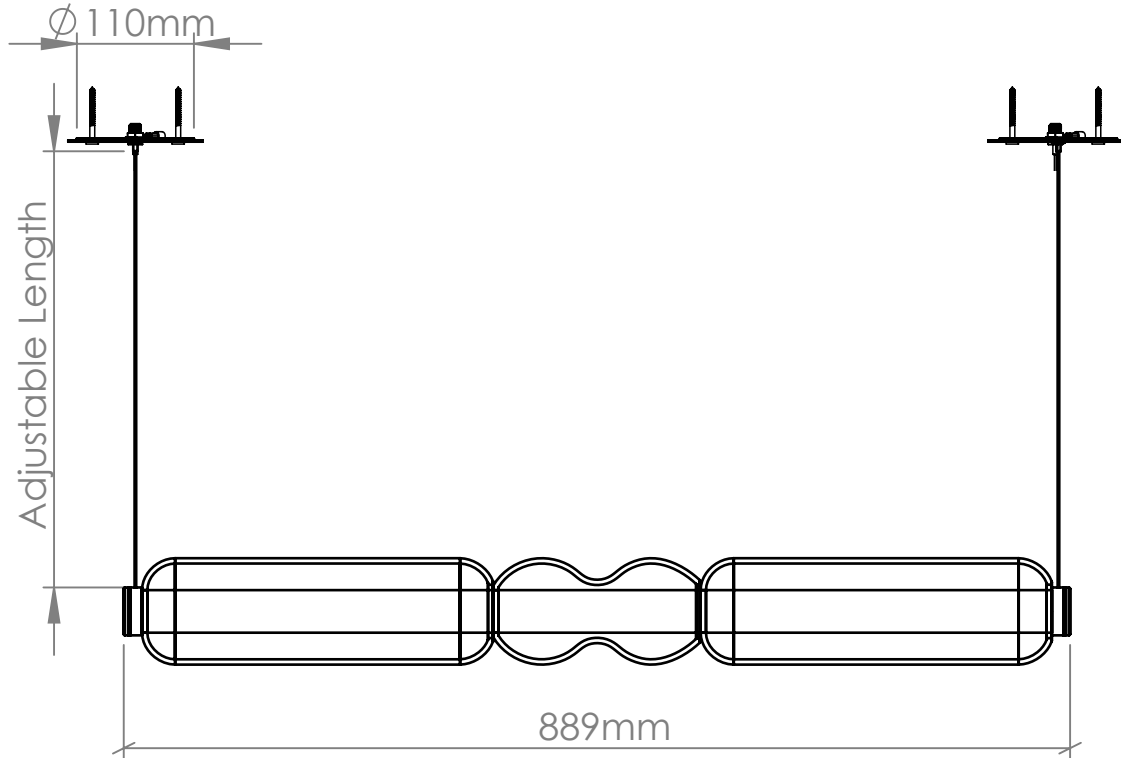

**PRODUCT CODE**  
VNS\_ELE

### MATERIALS

Free-blown glass, solid brass end caps.

### GLASS

Available in Clear in a transparent or sandblasted finish.

### FITTING

LED Strip [230V/24V] 2700k (Dimmable), approx. 32 Watts, approx. 1550 Lumens. With transformer. *American fittings [UL Rated] also available.*

### SUPPORT

1m adjustable powered suspension wire with cable gliders.

### AVERAGE WEIGHT

6kg

The lumen values stated are for the LEDS only.  
There will be an absorption factor of approx.  
30%-50% of this when taking into account the  
housing and the glass colour/finish.